

A. Decide on the correct template.  
 B. Fold on dotted lines, position on door and pilot drill fixing positions.

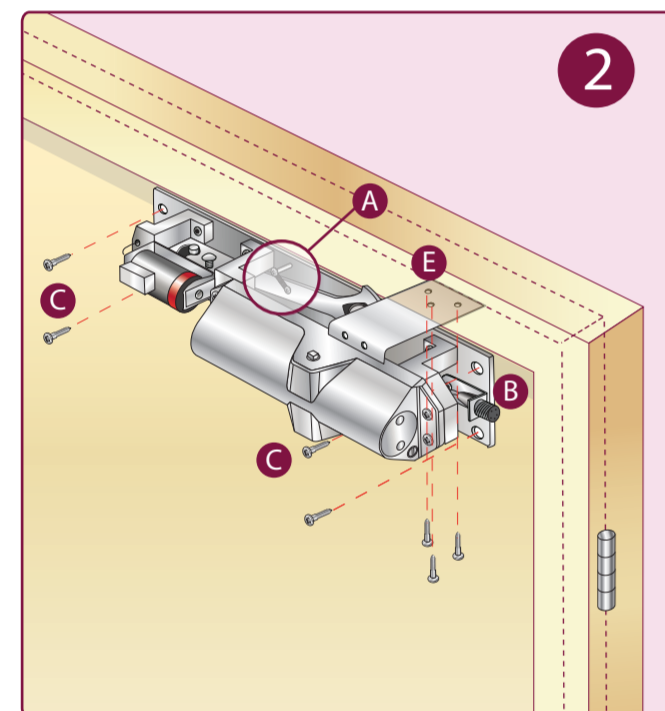

A. Position spring on the hold open catch plate to the top location pin.  
 B. Remove locking screw on electrical connection bracket to each end of the unit. Keep for later.  
 C. Fix closer to door with the electro magnet away from the hinge.  
 D. Refit the locking screw on both electrical connections.  
 E. Fix soffit bracket.

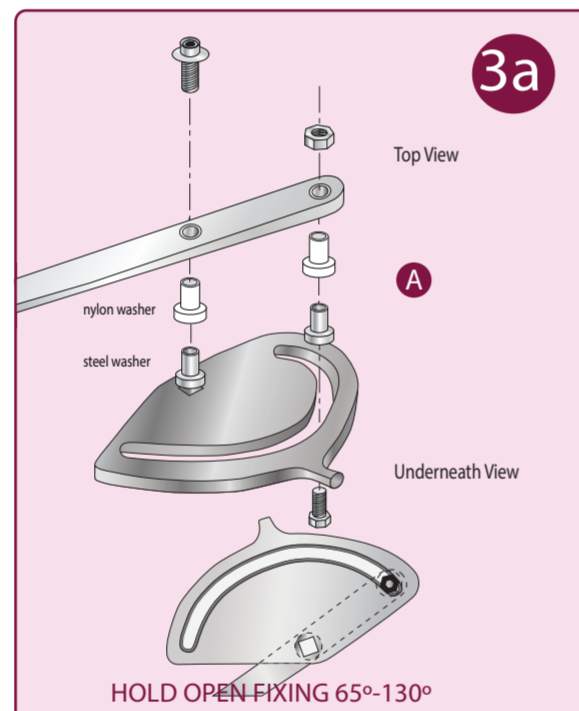
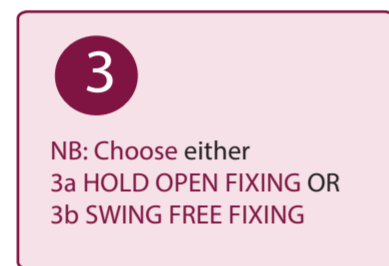

A. Fasten with bolt up through Arc Wheel and 1st hole in arm, fix with lock tight nut and shouldered washer between.

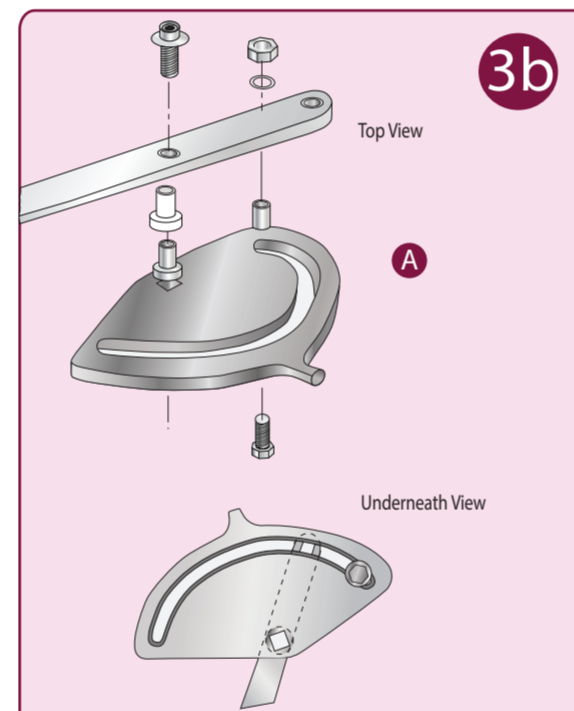

A. Fasten with bolt up through the Arc Wheel and fix through the collar spacer, lock tight nut and washer between. Do not fix through arm at this point.

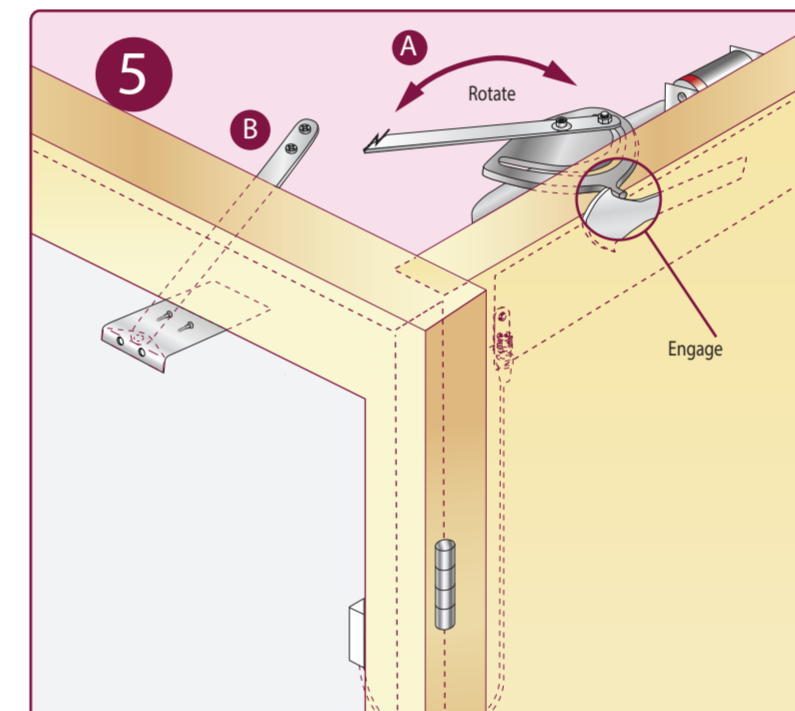

A. Open door and rotate pinion through 90° with arm and engage Arc wheel with Hold Open catch plate.  
 B. Separate the arm assembly and connect to the soffit bracket. Longest side of the shoe towards the hinge.  
 C. Fasten secondary arm together, switch off electricity so the closer shuts the door.  
 D. Adjust secondary arm so it holds parallel to the frame and tighten the two lock nuts.

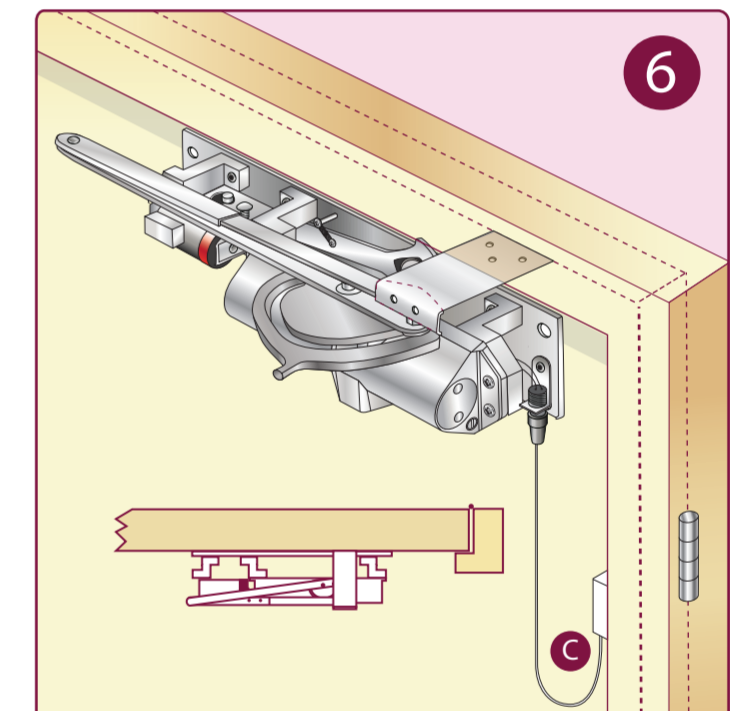

SET UP AND ADJUST  
 A. Adjust Closing Speed valve "1". This works from fully open to 15°. Turn clockwise to slow down the closing speed.  
 B. Adjust Latching Speed valve "2". This works from 15° to closed. Turn clockwise to slow down the latching speed.  
 C. Switch on electricity and re open the door to hold on the Catch Plate. Check and adjust door closer speed and latch option.  
 D. Fit door closer cover by first snapping out the desired parts.

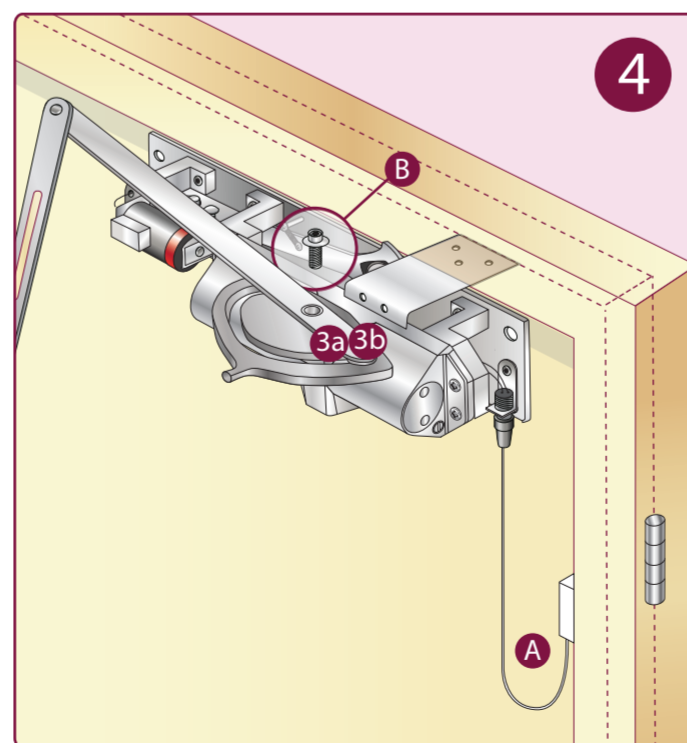
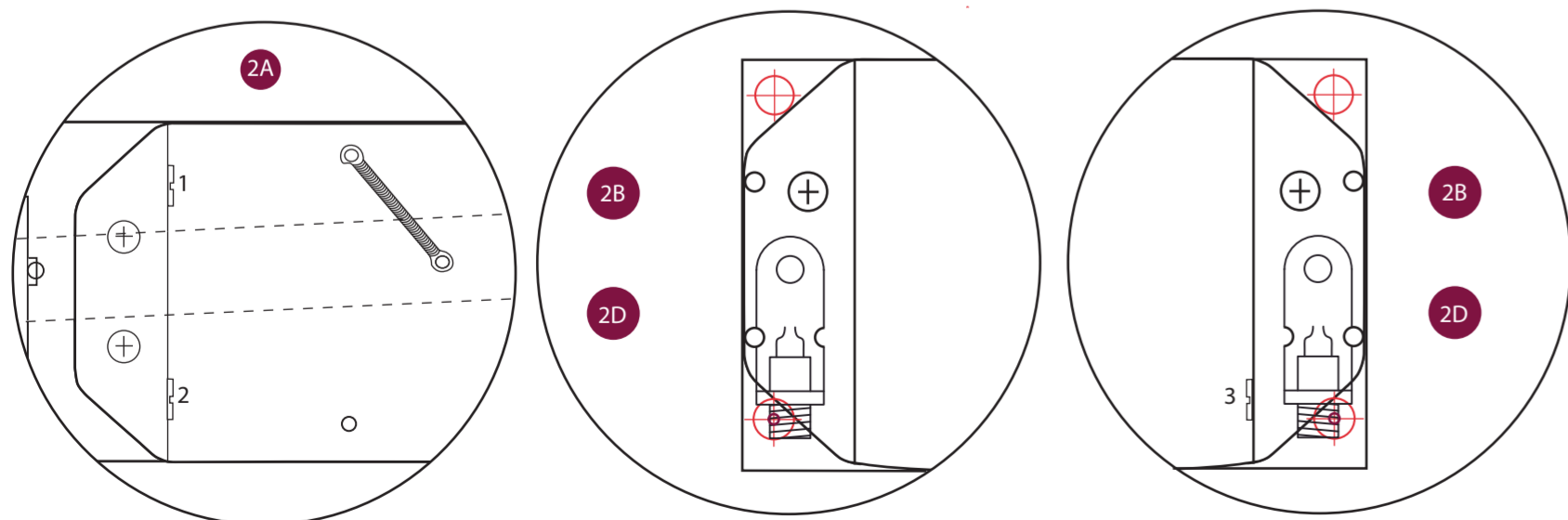

A. Connect the wiring as required to the junction box and plug the sockets together. Switch the electricity on.  
 B. Place Arc wheel on the pinion of the closer 90° to the front door facing out. Fit arm to pinion through Arc Wheel, with the long shoulder bolt, through the 2nd hole in arm with stainless shouldered washer and Nylon washer between.

MAINTENANCE  
 All parts that are visible when the cover is on should be checked and tightened every 3 months if required. Any worn or damaged part must be notified to the supplier upon observation.

7. FINISHING  
 To adjust the hold open or swing free angle on the Arc Wheel, first loosening the second nut and turn the door as required and retighten.

**RUTLAND** Responder 24  
Push Side fitting

www.rutlanduk.co.uk

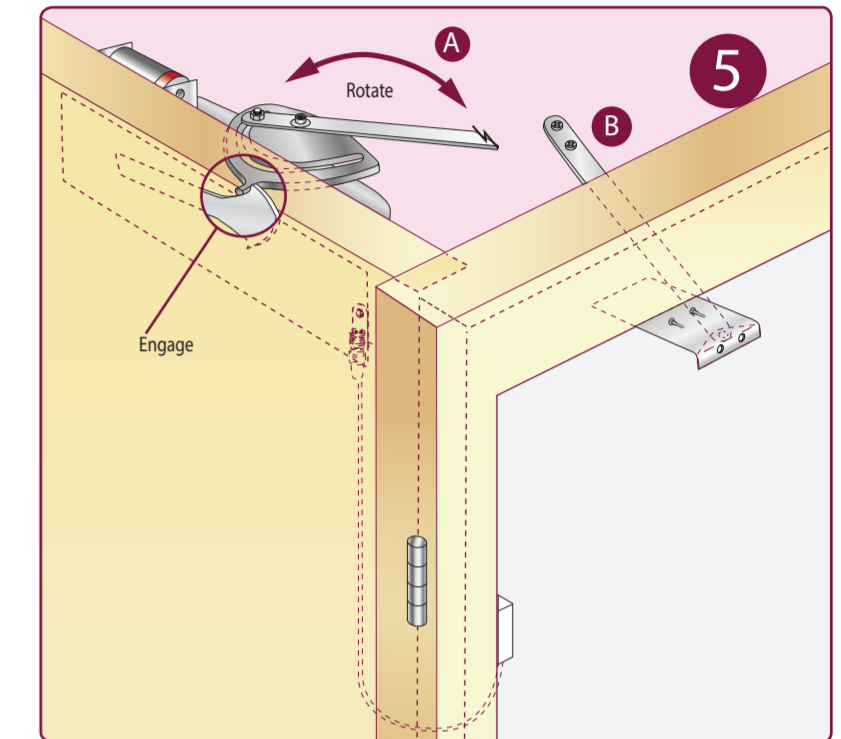
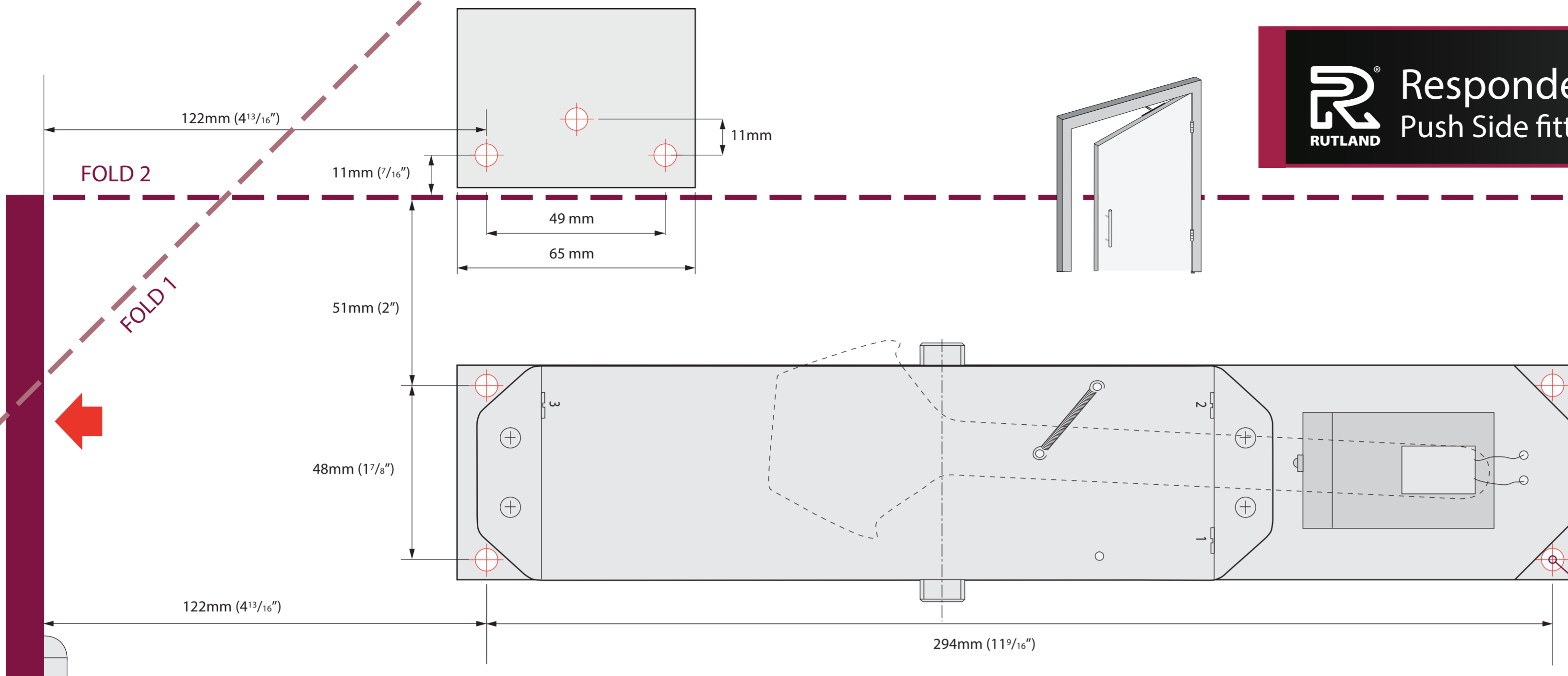

- A. Open door and rotate pinion through 90° with arm and engage Arc wheel with Hold Open catch plate.
- B. Separate the arm assembly and connect to the soffit bracket. Longest side of the show towards the hinge.
- C. Fasten secondary arm together, switch off electricity so the closer shuts the door.
- D. Adjust secondary arm so it holds parallel to the frame and tighten the two lock nuts.

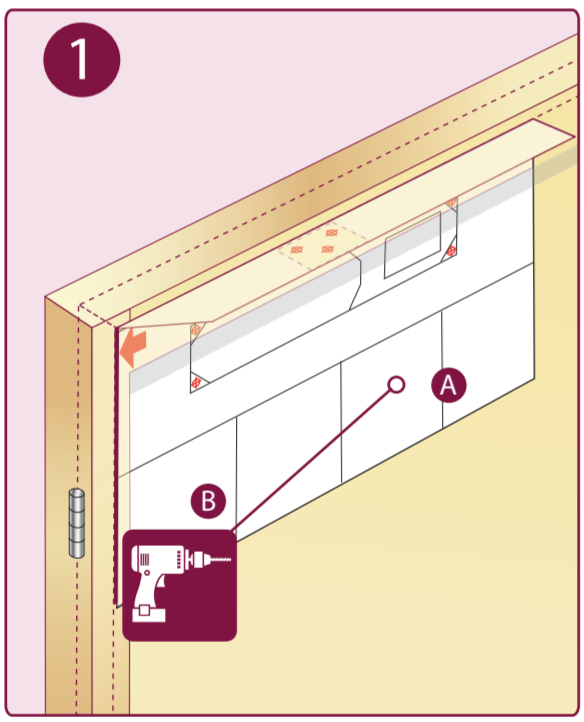

- A. Decide on the correct template.
- B. Fold on dotted lines, position on door and pilot drill fixing positions.

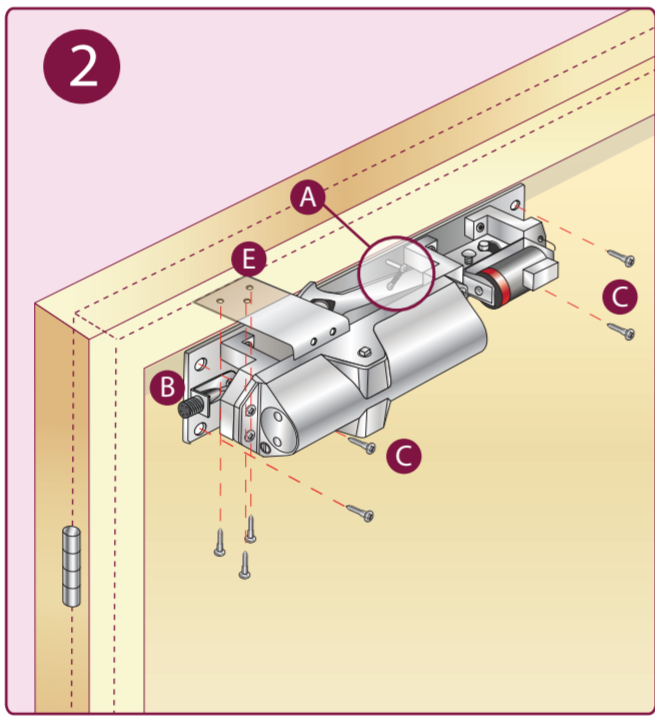

- A. Position spring on the hold open catch plate to the top location pin.
- B. Remove locking screw on electrical connection bracket to each end of the unit. Keep for later.
- C. Fix closer to door with the electro magnet away from the hinge.
- D. Refit the locking screw on both electrical connections.
- E. Fix soffit bracket.

**3**  
NB: Choose either  
3a HOLD OPEN FIXING OR  
3b SWING FREE FIXING

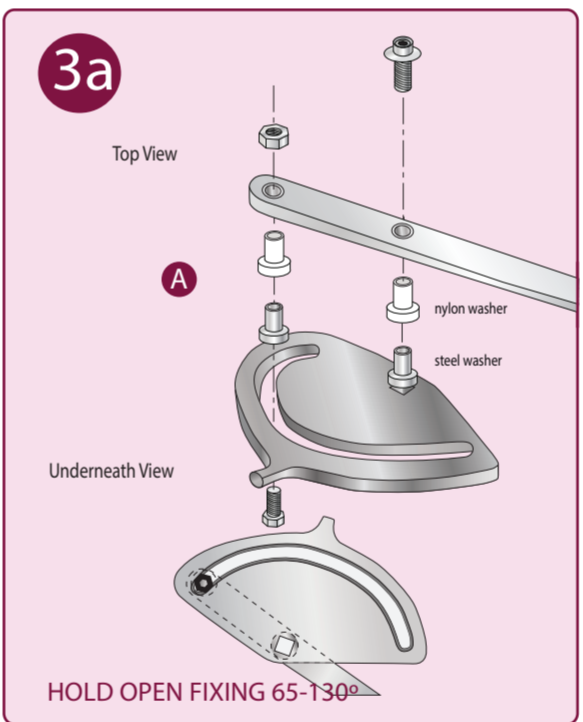

- A. Fasten with bolt up through Arc Wheel and 1st hole in arm, fix with lock tight nut and shouldered washer between.

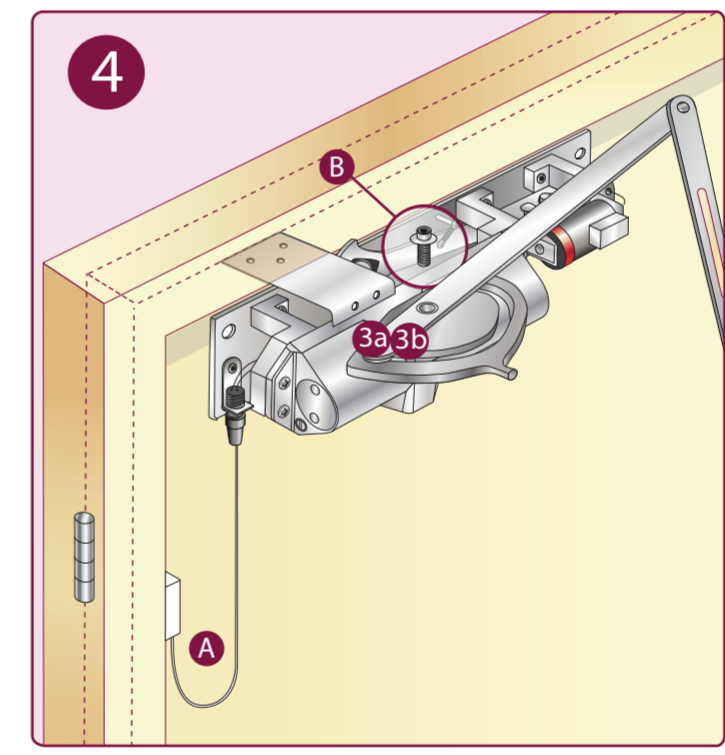

- A. Connect the wiring as required to the junction box and plug the sockets together. Switch the electricity on.
- B. Place Arc wheel on the pinion of the closer 90° to the front door facing out. Fit arm to pinion through Arc Wheel, with the long shoulder bolt, through the 2nd hole in arm with stainless shouldered washer and Nylon washer between.

**MAINTENANCE**  
All parts that are visible when the cover is on should be checked and tightened every 3 months if required. Any worn or damaged part must be notified to the supplier upon observation.

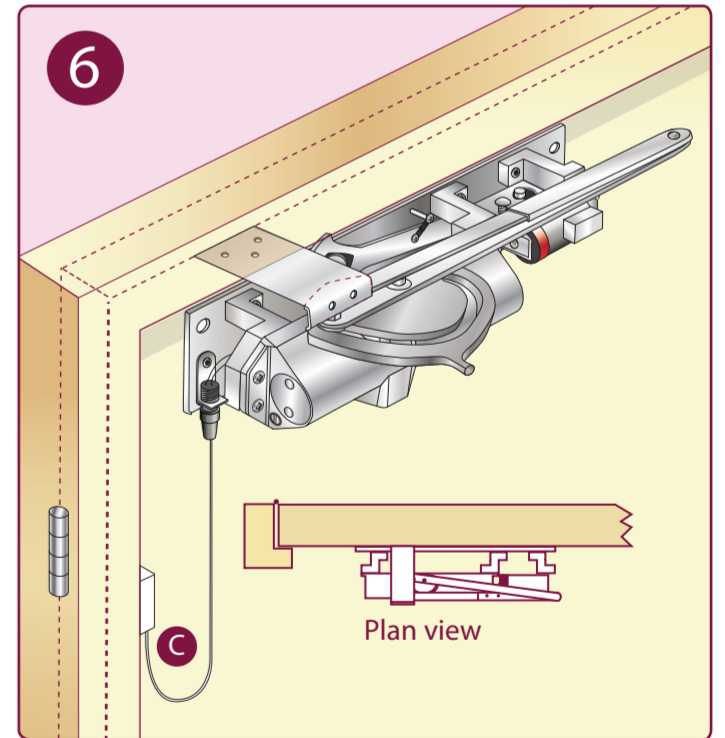

- SET UP AND ADJUST**
- A. Adjust Closing Speed valve "1". This works from fully open to 15°. Turn clockwise to slow down the closing speed.
  - B. Adjust Latching Speed valve "2". This works from 15° to closed. Turn clockwise to slow down the latching speed.
  - C. Switch on electricity and re open the door to hold on the Catch Plate. Check and adjust door closer speed and latch option.
  - D. Fit door closer cover by first snapping out the desired parts.

**7. FINISHING**  
To adjust the hold open or swing free angle on the Arc Wheel, first loosening the second nut and turn the door as required and retighten.

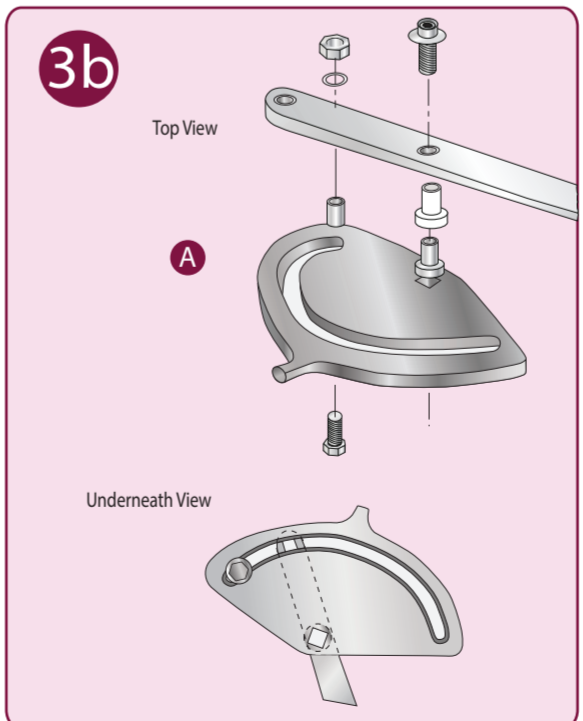
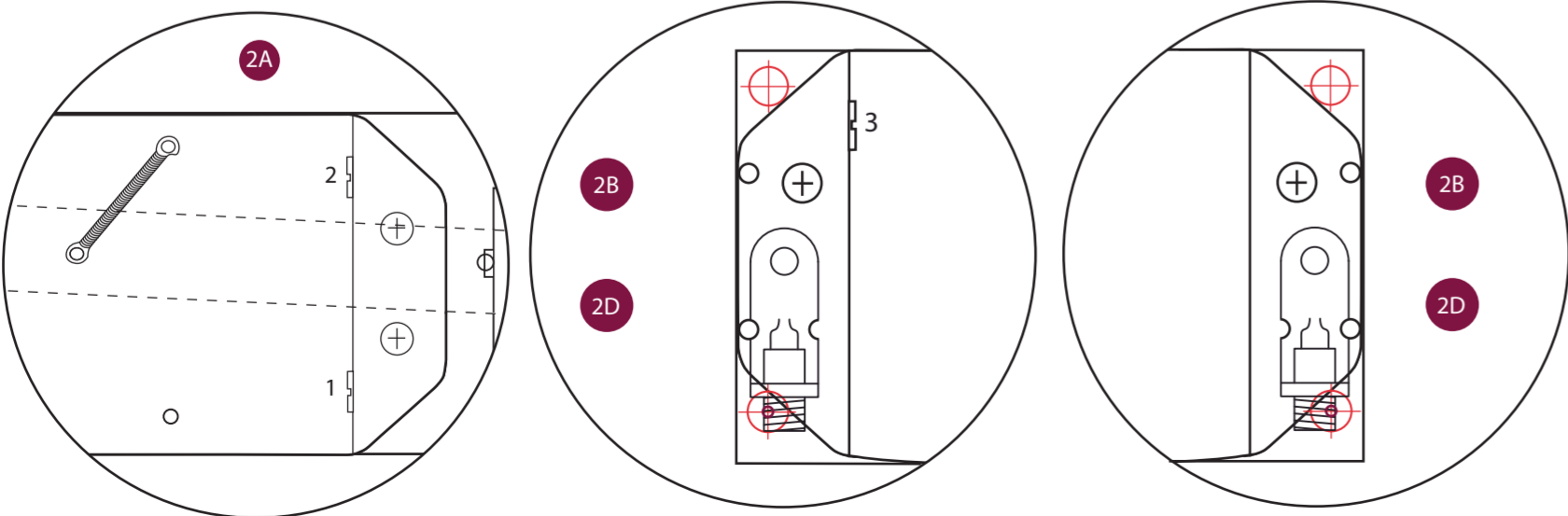

- A. Fasten with bolt up through the Arc Wheel and fix through the collar spacer, lock tight nut and washer between. Do not fix through arm at this point.

THE PINION BOLT MUST BE TIGHTENED TO 12NM

NO PART OF THIS INSTRUCTION CAN BE COPIED OR STORED IN ANY WAY OR FORM MANUALLY OR ELECTRONICALLY WITHOUT THE FULL PERMISSION OF RUTLAND